



**Ref. 07043**

**Acabado:** Satinado  
**Finitura:** Satinato



**Ref. 07044**

**Acabado:** Blanco mate  
**Finitura:** Bianco opaco



**Ref. 07045**

**Acabado:** Brillante  
**Finitura:** Brillante



**Ref. 07046**

**Acabado:** Negro mate  
**Finitura:** Nero opaco

## DESCRIPCIÓN DEL PRODUCTO DESCRIZIONE DEL PRODOTTO

Papelera accionada por pedal y tapa amortiguadora.  
*Pattumiera a pedale e coperchio con chiusura ammortizzata.*

Cubo interior de plástico con asa.  
*Cestino interno in plastica con maniglio.*

**Material:** Acero inoxidable.  
**Material:** Acciaio inossidabile.

**Capacidad:** 5 litros.  
**Capacità:** 5 litri.

## ESPECIFICACIONES TÉCNICAS SPECIFICHE TECNICHE

**Peso:** 0,85 kg  
*Peso*

**Dimensiones:** 265 x 205 x 250 mm  
*Dimensioni*

**Peso con embalaje:** 0,95 kg  
*Peso con imballo*

**Dimensiones con embalaje:** 260 x 220 x 220 mm  
*Dimensioni con imballo*

## PLANO SIMPLIFICADO PIANO SEMPLIFICATO

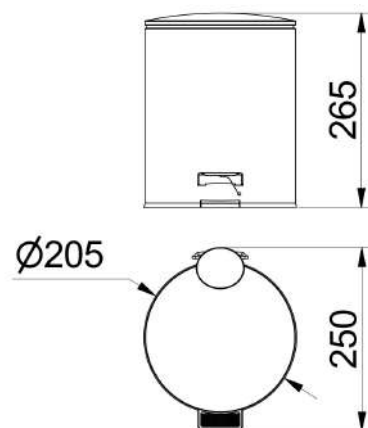



**Ref. 07039**  
Finish: Satin  
Finition: Satiné



**Ref. 07040**  
Finish: Matt white  
Finition: Blanc mat



**Ref. 07041**  
Finish: Polished  
Finition: Brillant



**Ref. 07042**  
Finish: Matt black  
Finition: Noir mat

### DESCRIPCIÓN DEL PRODUCTO DESCRIZIONE DEL PRODOTTO

Pedal operated bin and soft closing lid.  
*Poubelle à pédale et couvercle avec frein descente lente.*

Plastic interior container with handle.  
*Seau en plastique avec poignée.*

Material: Stainless steel.  
*Matériel: Acier inoxydable.*

Capacity: 3 liters.  
*Capacité: 3 litres.*

### TECHNICAL SPECIFICATIONS SPÉCIFICATIONS TECHNIQUES

Weight: 0,75 kg  
*Poids*

Dimensions: 240 x 170 x 220 mm  
*Dimensions*

Weight with packaging: 0,85 kg  
*Poids avec emballage*

Dimensions with packaging: 250 x 220 x 220 mm  
*Dimensions avec emballage*

### SIMPLIFIED PLAN PLAN SIMPLIFIÉ

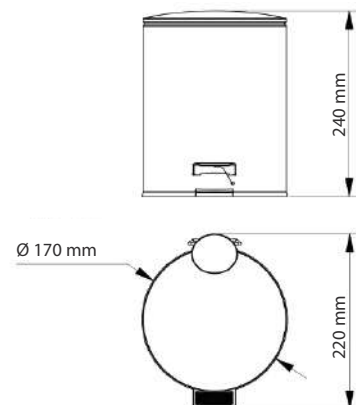



**Ref. 07039**  
**Acabado:** Satinado  
**Finitura:** Satinato



**Ref. 07040**  
**Acabado:** Blanco mate  
**Finitura:** Bianco opaco



**Ref. 07041**  
**Acabado:** Brillante  
**Finitura:** Brillante



**Ref. 07042**  
**Acabado:** Negro mate  
**Finitura:** Nero opaco

### DESCRIPCIÓN DEL PRODUCTO DESCRIZIONE DEL PRODOTTO

Papelera accionada por pedal y tapa amortiguadora.  
*Pattumiera a pedale e coperchio con chiusura ammortizzata.*

Cubo interior de plástico con asa.  
*Cestino interno in plastica con maniglio.*

**Material:** Acero inoxidable.  
**Material:** Acciaio inossidabile.

**Capacidad:** 3 litros.  
**Capacità:** 3 litri.

### ESPECIFICACIONES TÉCNICAS SPECIFICHE TECNICHE

**Peso:** 0,75 kg  
*Peso*

**Dimensiones:** 240 x 170 x 220 mm  
*Dimensioni*

**Peso con embalaje:** 0,85 kg  
*Peso con imballo*

**Dimensiones con embalaje:** 250 x 220 x 220 mm  
*Dimensioni con imballo*

### PLANO SIMPLIFICADO PIANO SEMPLIFICATO

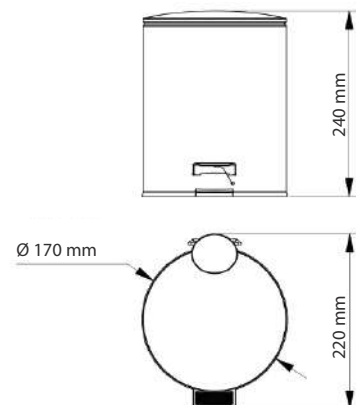



**Ref. 07043**  
Finish: Satin  
Finition: Satiné



**Ref. 07044**  
Finish: Matt white  
Finition: Blanc mat



**Ref. 07045**  
Finish: Polished  
Finition: Brillant



**Ref. 07046**  
Finish: Matt black  
Finition: Noir mat

### DESCRIPCIÓN DEL PRODUCTO DESCRIZIONE DEL PRODOTTO

Pedal operated bin and soft closing lid.  
*Poubelle à pédale et couvercle avec frein descente lente.*

Plastic interior container with handle.  
*Seau en plastique avec poignée.*

Material: Stainless steel.  
*Matériel: Acier inoxydable.*

Capacity: 5 liters.  
*Capacité: 5 litres.*

### TECHNICAL SPECIFICATIONS SPÉCIFICATIONS TECHNIQUES

Weight: 0,85 kg  
*Poids*

Dimensions: 265 x 205 x 250 mm  
*Dimensions*

Weight with packaging: 0,95 kg  
*Poids avec emballage*

Dimensions with packaging: 260 x 220 x 220 mm  
*Dimensions avec emballage*

### SIMPLIFIED PLAN PLAN SIMPLIFIÉ

